

**MULE-HIDE 2.4" BARBED SEAM PLATES**

**PRODUCT DESCRIPTION**

Mule-Hide's 2.4" Barbed Seam Plates are round Galvalume coated metal plates with (14) barbed anchors and reinforcing ribs for superior wind uplift resistance.

PART NO.	PCS / BKT	WEIGHT / BKT
700485	1000	52 LBS

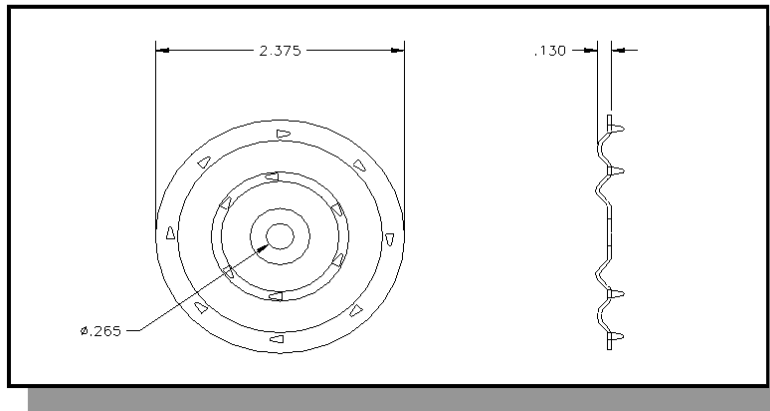

**BASIC USES**

Mule-Hide's 2.4" Barbed Seam Plates are designed for the mechanical attachment of the Mule-Hide Reinforced EPDM, PVC and TPO membranes. The 2.4" Barbed Seam Plates can also be used with the Mule-Hide reinforced 6" wide RMS, or 6" wide and 10" wide RUSS™ Strip.

**SPECIFICATIONS**

The Mule-Hide 2.4" Barbed Seam Plates are constructed from 20 gauge Galvalume coated metal.

- Coating: Galvalume AZ 55 meeting ASTM A 792 Grade 50A
- Corrosion: Meets FM corrosion standard 4470
- Pull Thru: Flat truss head pulled through the center hole of the plate, minimum pull thru: 800 lbs.

**TECHNICAL SERVICES**

Contact Mule-Hide Products Co., Inc. at 608/365-3111 for additional information.

**DISCLAIMER**

The statements provided concerning the material shown are intended as a guide for material usage and are believed to be true and accurate. No statement made by anyone may supersede this information, except when done in writing by Mule-Hide Products Co., Inc. Since the manner of use is beyond our control, Mule-Hide does not make nor does it authorize anyone to make any warranty of merchantability or fitness for any particular purpose or any other warranty, guarantee or representation, expressed or implied, concerning this material except that it conforms to Mule-Hide's physical properties. Buyer and user accept the product under these conditions and assume the risk of any failure, any injury of person or property (including that of the user), loss or liability resulting from the handling, storage or use of the product whether or not it is handled, stored or used in accordance with the directions or specifications. Mule-Hide must be notified in writing of any claims and be given the opportunity to inspect the complaint or failure before repairs are made.

RUSS™ is a Trademark of Carlisle Syntec.

Form # PDS-ACC-7  
Date 01/01/2007

**MULE-HIDE PRODUCTS CO., INC.**

P.O. Box 1057, Beloit, WI 53512-1057 • 608/365-3111 • Fax: 608/365-7852